

Folding B-Dawg Instructions

Step 1:

Make sure you have the Hitch Tube, Main Tray Tube, 5/8" brass pins (x4), and Tilt Bracket.

Figure 1

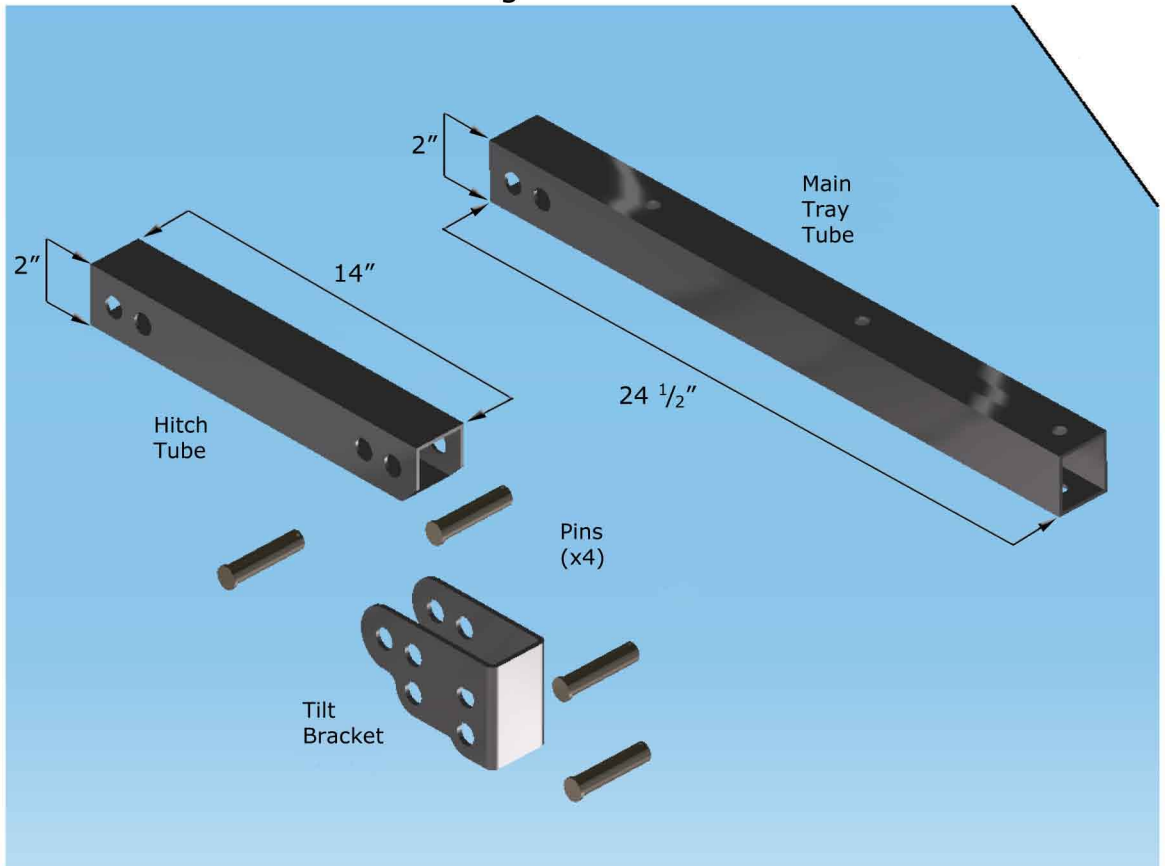

Step 2:

Place bracket upright. Lay main tray tube on bottom of bracket so that the two holes line up with the holes in the bracket. Insert brass pins and cotter pins. In the two holes just above the main tray tube, place the shorter hitch tube with the angled end toward the bracket and face down next to the main tray tube, as shown in Figure 2. Place two other brass pins through the bracket and hitch tube along with the corresponding cotter pins. There should be one empty hole on the bracket at the top. The extended tray position should look like Figure 2.

Figure 2

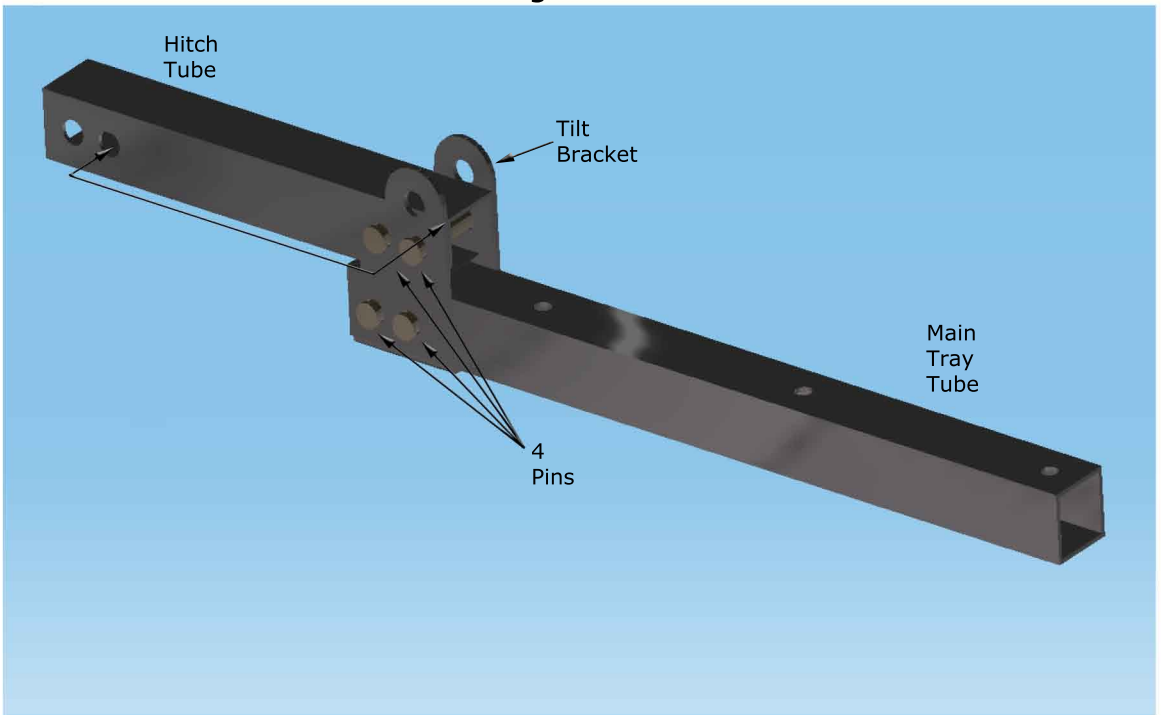

Step 3:

To fold the carrier upright, only 1 pin needs to be removed. The pin in the hitch tube and bracket closest to the vehicle should be removed, as shown in Figure 3.

Figure 3

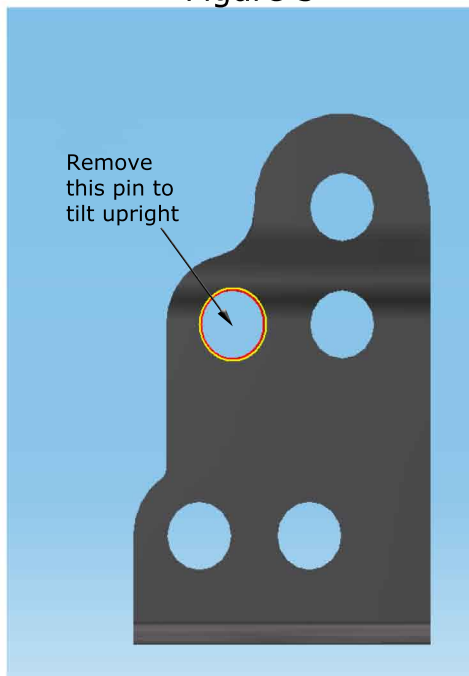

The tray can then be rotated upright. Return the pin and cotter pin to the hole in the bracket which was previously unoccupied. This should lock the carrier upright. See Figure 4 and 5 for details. If you have questions please contact www.hitchcarriers.com.

Figure 4

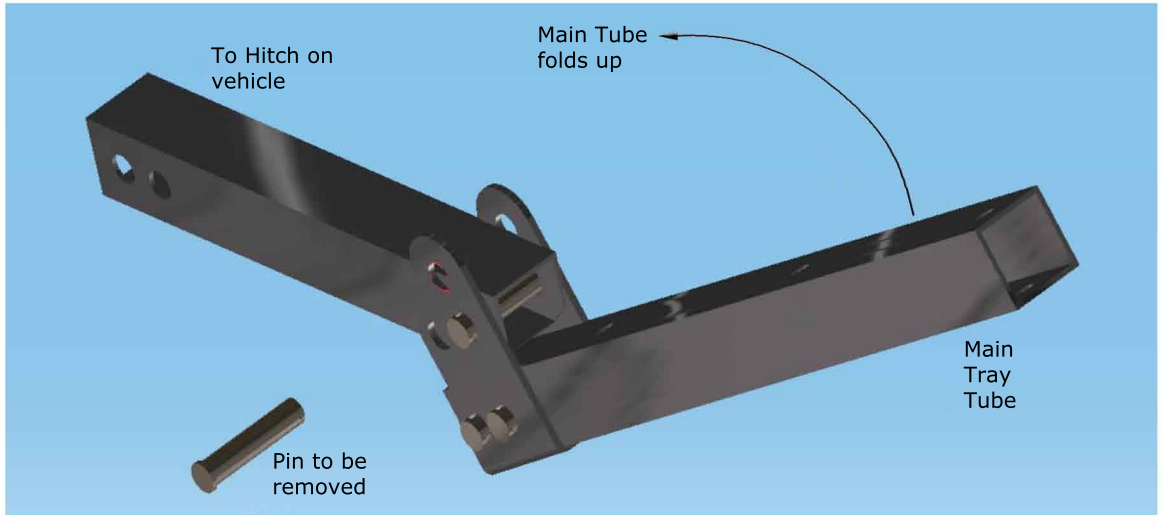
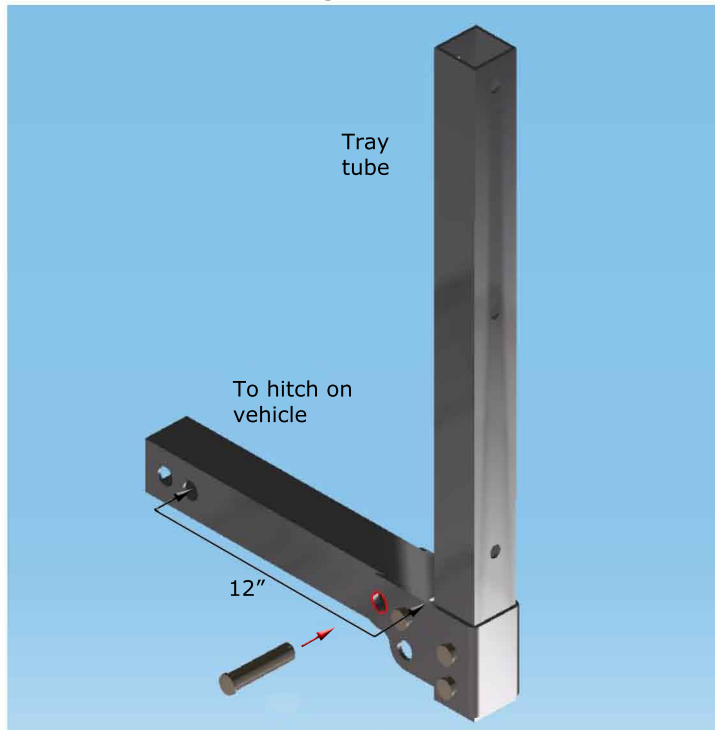

Figure 5



In the folded position, the distance from the center of hitch pin to the main tray tube is 12". In addition, you should account for the height of the attached tray (3" or 5" version).